

EPE6047S & EPE6047S-RC



- Designed for use with Seeq 83C95
- General Purpose 10Base-T Filter Module
- Complies with or exceeds IEEE 802.3, 10Base-T Standards
- Add "-RC" after part number for RoHS Compliant
- Available in SMD, DIP & DIL Packages
Optional Tape and Reel Packaging
- Hipot : 2000 Vrms

Electrical Parameters @ 25° C

Inductance ($\mu\text{H} \pm 20\%$)		Interwinding Capacitance (pF Max.)	Leakage Inductance ($\mu\text{H} \text{ Max.}$)		Et Prodcut (V- μS Typ.)	Rise Time (nS Max..)	DCR (Max.)	
@100 KHz, 0.1 Vrms		@100 KHz, 0.1 Vrms	@100 KHz, 0.1 Vrms					
Xmit	Rcv	from Input to Output	Xmit	Rcv			Xmit	Rcv
400	100	10	0.30	0.17	2.0	3.0	0.45	0.30
Pins 1-3	Pins 6-8		Pins 16-14 w/ 1,2,3 shorted	Pins 6-8 w/ 9,10,11 shorted			Pins 1-3	Pins 6-8, 11-9, 16-14

- **Isolation** : meets or exceeds 802.3 IEEE Requirements •

Package

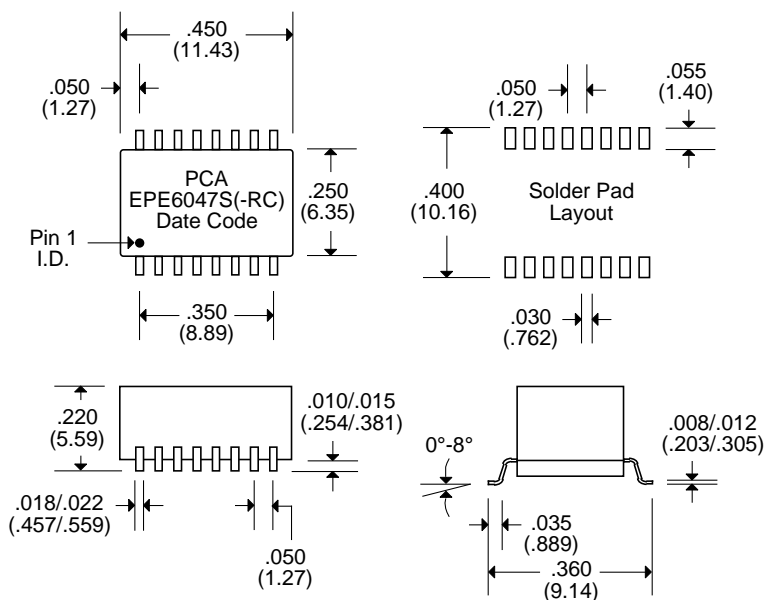

Schematic

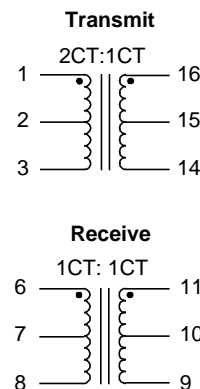

Notes :	EPE6047S	EPE6047S-RC
1. Lead Finish	SnPb	Hot Tin Dip (Sn) †
2. Peak Temperature Rating	225°C	245°C
3. Moisture Sensitive Levels	MSL = 3 (168 Hours, 30°C/60%RH)	MSL = 4 (72 Hours, 30°C/60%RH)
4. Weight	1.02 grams	1.02 grams
5. Packaging Information (*Add "TR" to end of part number, but in front of "-RC" when placing order)	(Tube) TBD pieces/tube	TBD pieces/tube
	(Tape & Reel) TBD pieces/13" reel (*EPE6047STR)	TBD pieces/13" reel (*EPE6047STR-RC)

† Lead Material : Matte Tin with Ni Barrier

Unless Otherwise Specified Dimensions are in Inches /mm $\pm .010 / .25$